



Introduction..... 2  
Harmonics Chart.....3  
Chord Index.....4  
Chord Diagrams.....5  
Scales, Cycles and Progressions.....20  
My Favorites.....24  
Licks.....27

# ***HARMONICS***

*Jayne Publications*

P.O. BOX 175 MALDEN, MA. 02148

*by*

Copyright © 1981

***Barry Sahagian***

## Harmônicos

Examine os diagramas cuidadosamente, Foram usados *Harmônicos* no quarto, quinto, sexto e sétimo trastes quase que exclusivamente, com a exceção de alguns exemplos. Nestas quatro posições (em um baixo de 4 cordas) encontram-se todas as notas de uma escala cromática exceto Bb e Eb, quatro escalas maiores e inúmeros acordes. Foram incluídos 90 acordes usando-se todos os tons.

Estes acordes são formados inteiramente por *harmônicos*, ou por duas ou três notas harmônicas, mais uma nota tocada normalmente. Acrescentando uma nota “normal” às estruturas de *Harmônicos*, enriquece e multiplica as possibilidades do uso de *Harmônicos*, como você verá. A maioria dos acordes tem a tônica como nota mais grave, o que torna os acordes mais funcionais, numa situação real. Muitos dos acordes não se conseguem tocar com um só ataque. Exemplos no final do livro demonstram este tipo de abordagem.

Nos DIAGRAMAS de acordes, um QUADRADO representa um *Harmônico*. Um CÍRCULO representa uma nota tocada normalmente.

Nos exemplos de PARTITURA, um pequeno círculo sobre uma nota, representa um *Harmônico*; uma nota sem o círculo deverá ser tocada normalmente. Lembre-se que o *Harmônico* deverá ser tocado em uma das quatro posições (trastes) mencionados anteriormente, a não ser que seja indicada uma outra opção no exemplo específico. Tocar um *Harmônico* em posição errada produzirá uma nota diferente.

Dica: depois que estiver dominando alguns dos exemplos deste livro, pratique-os em músicas que você já toca com sua banda e comece a empregá-los quando tocarem juntos, não se esquecendo de observar as expressões de surpresa e admiração dos outros músicos à medida que você cuidadosamente e com bom gosto ornamenta a música com “delicadas explosões de cores”.

Palavras chaves;

Inglês Português

Fret = Traste.

Nota do tradutor;

*Harmônicos* são como um bom perfume; use-os na medida certa e todos vão querer estar (tocar) com você.

## H A R M O N I C S

Look over the charts carefully. I have used the harmonics on the Fourth, Fifth, Sixth and Seventh positions almost exclusively with the exception of a few examples. Within these four positions are all the notes in a Chromatic Scale except Bb and Eb, Four Major Scales and countless Chords. I have included 90 of them in all keys.

These Chords are made up of two or three Harmonic notes plus one Fretted note or entirely by Harmonic notes. Adding Fretted notes to the Harmonic structures multiply the possibilities of Harmonic playing, as you will see. Most of the Chords have the root for the lowest note which make them more functional in a playing situation. Many of the Chords cannot be played completely with one attack. My examples in the latter part of the Book illustrate various approaches on this matter.

On the Chord Diagram a SQUARE represents a Harmonic Note. A CIRCLE represents a normally Fretted Note as illustrated.

On the written Examples, a SMALL CIRCLE over the note represents a Harmonic Note; NO CIRCLE represents a normally Fretted Note. Remember, that the Harmonic Notes must be played in one of the four positions indicated unless I have remarked otherwise. To play a Harmonic Note in the wrong position will produce a different note.

After you have a few of these Chords under your fingers; work a few of them into some of the songs that you do on your gig or session. Then watch for looks of surprise on fellow band member's faces as you tastefully create splashes of color that do nothing less than make you sound like the well-rounded Bassist.

Barry Sahagian

# Chord Index

<p><b>C</b></p> <p>C SUS . . . . . 23    C LYD . . . . . 26            C MAJ 7, 13 . . . . 1    C° . . . . . 43            C TRIAD . . . . . 12    C MAJ 9#11 . 52            C MAJ 13 . . . . . 16    C- . . . . . 73                                              C+ . . . . . 81</p>	<p><b>F#</b></p> <p>F#- TRIAD . . . 6    F#-9 . . . . . 84            F# SUS . . . . . 37    F# . . . . . 91            F# TRIAD . . . 70            F#- TRIAD . 83</p>
<p><b>D<sup>b</sup></b></p> <p>D<sup>b</sup> MAJ 7 . . . . 17    D<sup>b</sup> 7 . . . . . 65            D<sup>b</sup> LYD . . . . . 47    D<sup>b</sup>- . . . . . 82            D<sup>b</sup> LYD . . . . . 48    D<sup>b</sup> SUS . . . . 86            D<sup>b</sup>- . . . . . 53    D<sup>b</sup> MAJ TRIAD . 64</p>	<p><b>G</b></p> <p>G TRIAD . . . . 5    G- . . . . . 71            G MAJ 7#11 . 14    G MAJ 7, 13 . 76            G MAJ 7 . . . . 18            G SUS . . . . . 22</p>
<p><b>D</b></p> <p>D MAJ 7 . . . . . 2    D MAJ 9 . . . . 46            D SUS 9 . . . . . 10    D MAJ 7 . . . . 57            D- . . . . . 21    D 7 . . . . . 77            D MAJ 13 . . . 32    D TRIAD . . . . 85</p>	<p><b>A<sup>b</sup></b></p> <p>A<sup>b</sup> MAJ 7 . . . . 9    A<sup>b</sup> 7<sup>b</sup> 5 . . . . 88            A<sup>b</sup>° . . . . . 42    A<sup>b</sup> MAJ 7 . . . 90            A<sup>b</sup>- . . . . . 59    A<sup>b</sup> Δ 7#11 . . . 40            A<sup>b</sup> LYD . . . . 80</p>
<p><b>E<sup>b</sup></b></p> <p>E<sup>b</sup> MAJ 9, 13 . . 15    E<sup>b</sup> 9, 13 . . . . 51            E<sup>b</sup> LYD . . . . . 25    E<sup>b</sup> 7 . . . . . 55            E<sup>b</sup>- MAJ 7 . . . 29    E<sup>b</sup> 7<sup>b</sup> 5 . . . 56            E<sup>b</sup>- . . . . . 50    E<sup>b</sup>-9 . . . . . 61</p>	<p><b>A</b></p> <p>A 7 . . . . . 8    A MAJ 9, 13 . . 4            A MAJ . . . . . 20    A SUS 9 . . . . 54            A SUS . . . . . 33    A MAJ 7 . . . . 58            A SUS . . . . . 34    A-7 . . . . . 63</p>
<p><b>E</b></p> <p>E DOM 7, 13 . . 3    E MAJ 9 . . . . 39            E-7 . . . . . 19    E 7#9 . . . . . 79            E 7 . . . . . 31    E MAJ 9, 13 . 72            E TRIAD . . . . 38    E-9 . . . . . 68                                              E° . . . . . 41</p>	<p><b>B<sup>b</sup></b></p> <p>B<sup>b</sup> MAJ 7, 13 . . 11            B<sup>b</sup> LYD . . . . . 13    B<sup>b</sup>- . . . . . 49            B<sup>b</sup>- Δ 7 . . . . 27    B<sup>b</sup>-9 . . . . . 62            B<sup>b</sup> 9 . . . . . 28    B<sup>b</sup> 7 . . . . . 66            B<sup>b</sup> TRIAD . 89    B<sup>b</sup> 6 . . . . . 67</p>
<p><b>F</b></p> <p>F MAJ 9 . . . . . 24    F 6 . . . . . 78            F- . . . . . 35            F-9 . . . . . 36            F- . . . . . 69</p>	<p><b>B</b></p> <p>B-9 . . . . . 7    B- . . . . . 60            B-7 . . . . . 30    B TRIAD . . . . 74            B° . . . . . 44    B MAJ 9 . . . . 75            B MAJ 9 . 45    B MAJ 7, 9, 13 . 87</p>

# Harmonics Chart

7th fret harmonics same as fretted note

6th fret harmonics a major 3rd from fretted note

5th fret harmonics a 5th from fretted note

4th fret harmonics same as fretted note

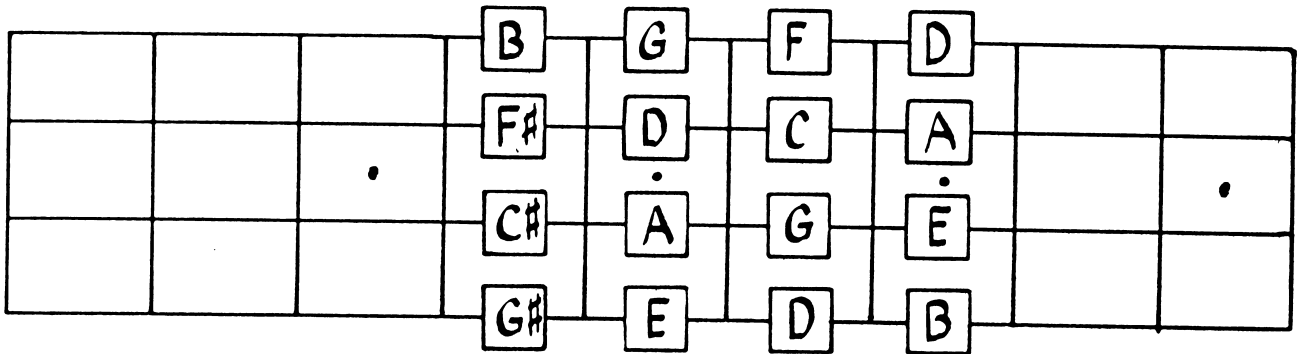

= Harmonic note

=



= Fretted note

=



= Either

1 C MAJ 7, 13

3rd fret

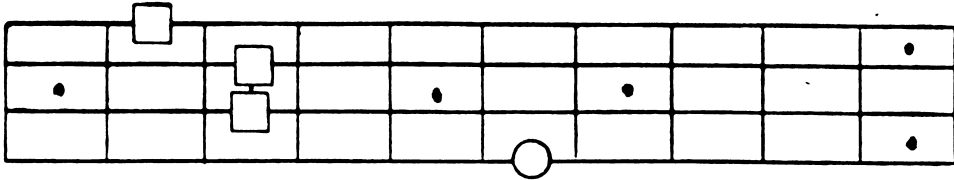

B  
D,  
A  
C

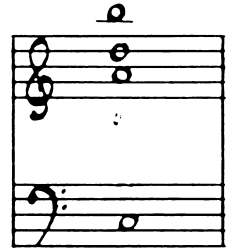

2 D MAJ 7

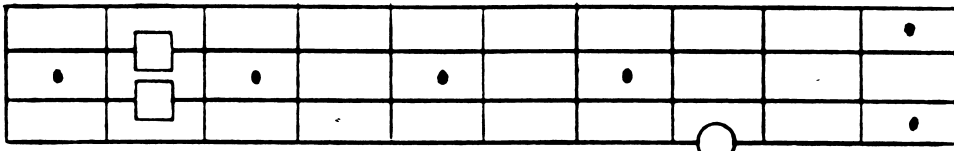

F#  
C#  
D

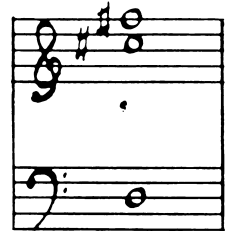

3 E 7, 13

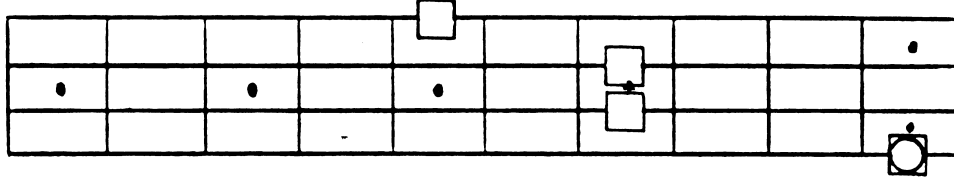

D  
F#  
C#  
E

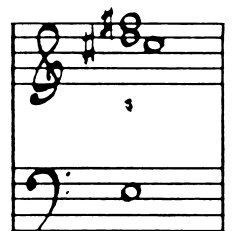

4 A MAJ 9, 13

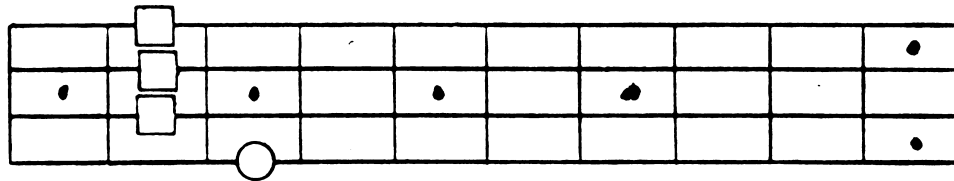

B  
F#  
C#  
A

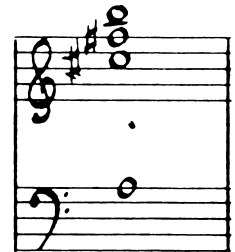

5 G MAJ TRIAD

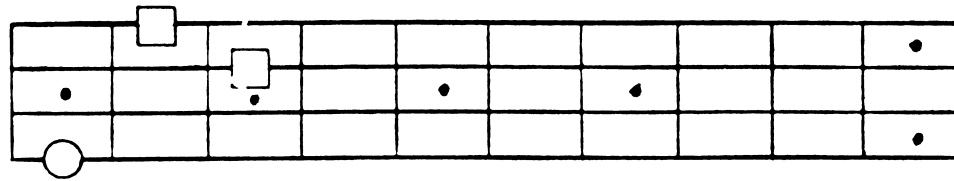

B  
D,  
G

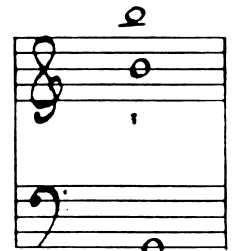

6 F# - TRIAD

1st fret

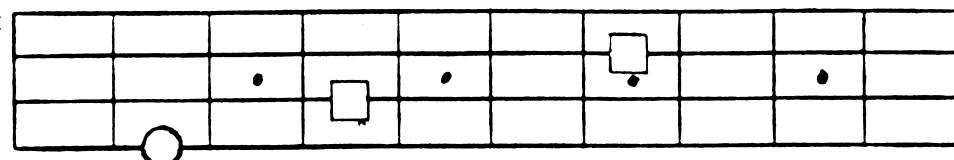

A  
C#  
F#



3rd Fret

7 **B-9**

D  
A  
C#  
B

8 **A7**

G  
A  
C#  
E

9 **A<sup>b</sup> MAJ 7**

C  
G  
Ab

10 **D SUS 9**

G  
A  
E  
D

11 **B<sup>b</sup> MAJ 7, 13**

G  
D  
Ab  
B

12 **C MAJ Triad**

G  
E  
C



13

B<sup>b</sup> LYD

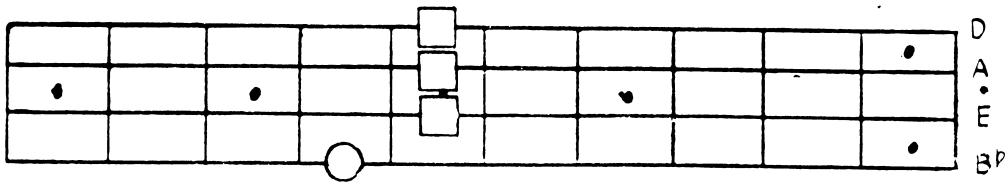

D  
A  
E  
B<sup>b</sup>

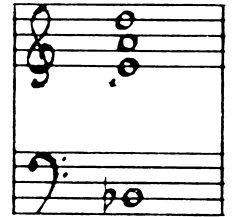

14

G LYD

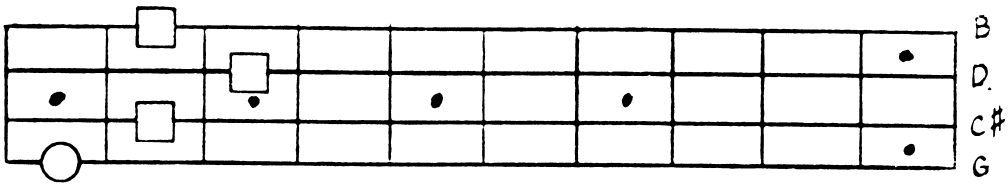

B  
D  
C<sup>#</sup>  
G



15

E<sup>b</sup> MAJ9,13

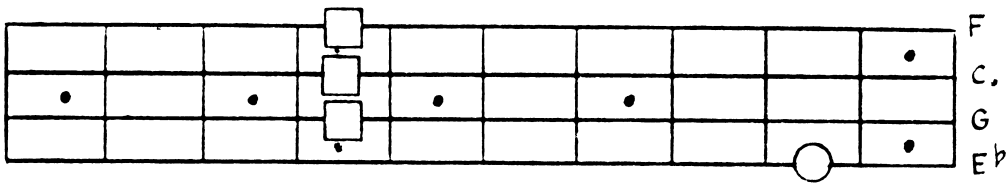

F  
C  
G  
E<sup>b</sup>

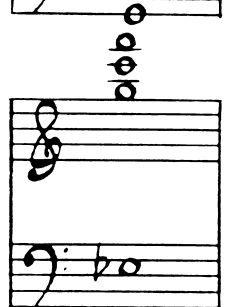

16

C MAJ 9,13

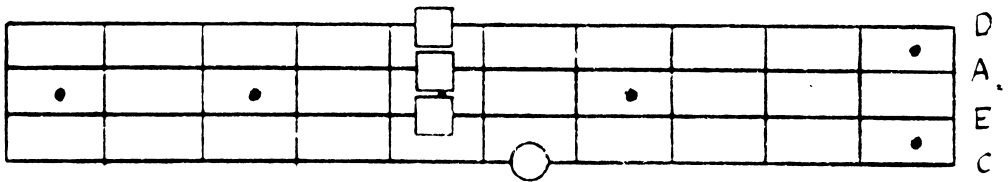

D  
A  
E  
C

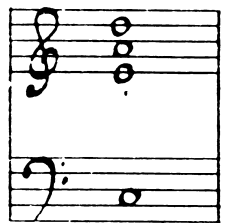

17

D<sup>b</sup> MAJ 7

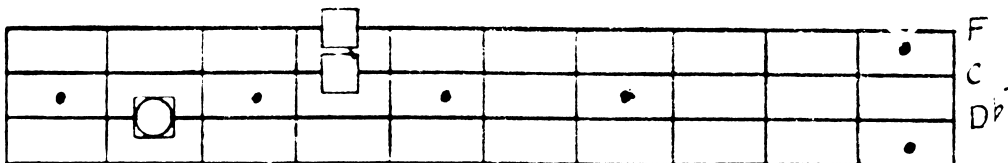

F  
C  
D<sup>b</sup>

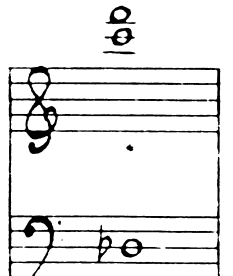

18

G MAJ 7

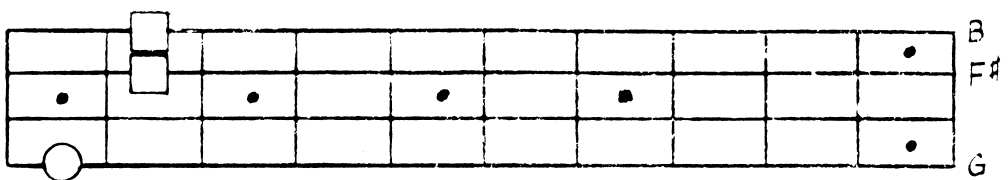

B  
F<sup>#</sup>  
G



19

E-7

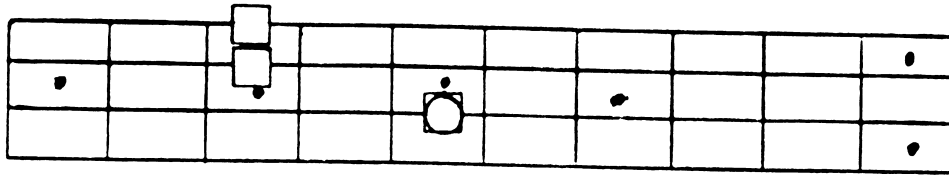

E, G, B

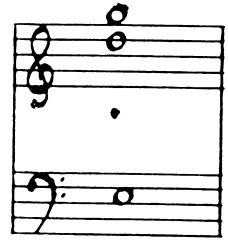

20

A MAJ

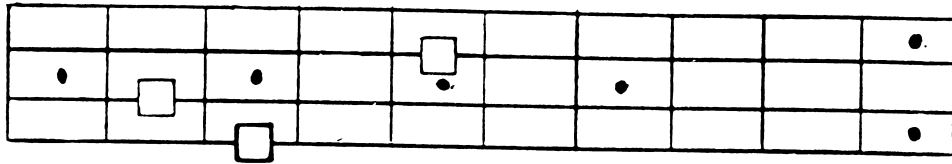

A, C, E



21

D-

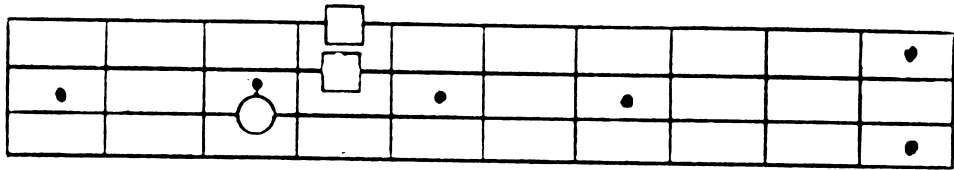

F, A, D

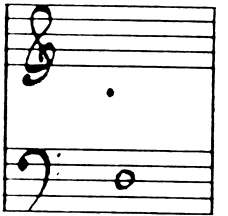

22

G SUS

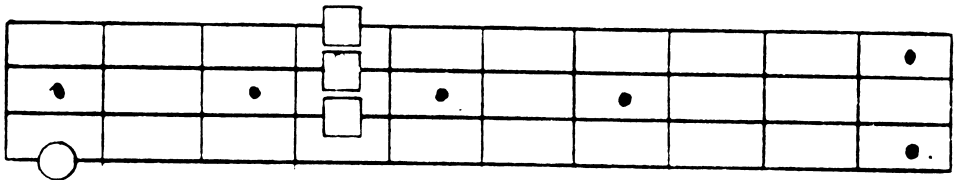

F, C, G

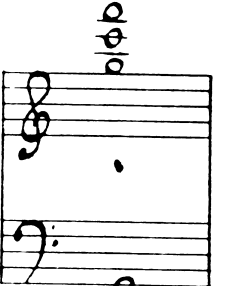

23

C SUS

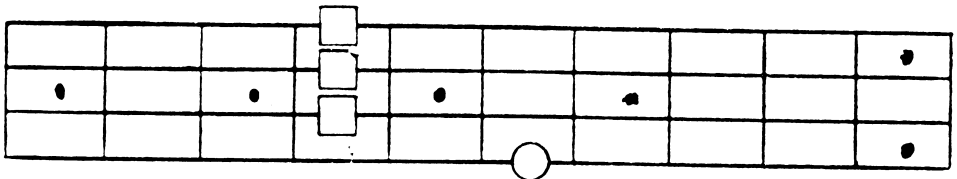

F, C, G

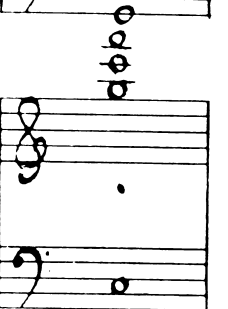

24

F MAJ 9

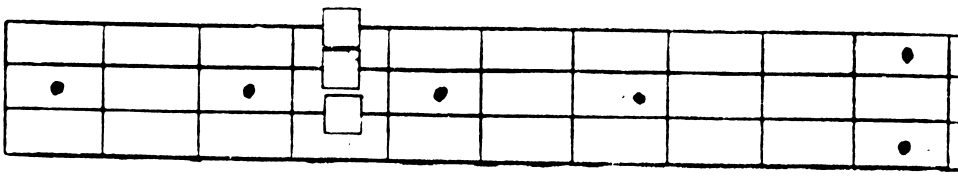

F, C, A

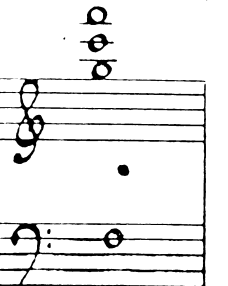

25  $E^b$  LYD

D  
A  
•  
 $E^b$

26 C LYD

B  
F#  
 $E^b$   
C

27  $B^b$ - MAJ 7

A  
 $D^b$   
 $B^b$

28  $B^b$  9

F  
C  
 $B^b$

29  $E^b$ - MAJ 7

D  
 $G^b$   
 $E^b$

30 B-7

D  
A  
•  
B

31

E 7

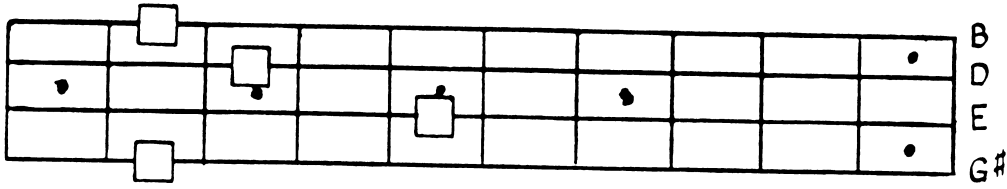

B  
D  
E  
G#

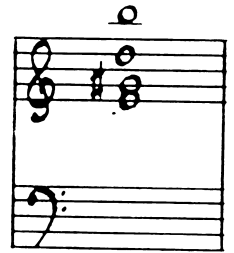

32

D MAJ 13

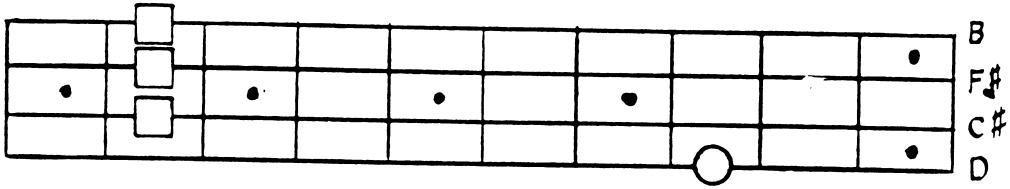

B  
F#  
C#  
D

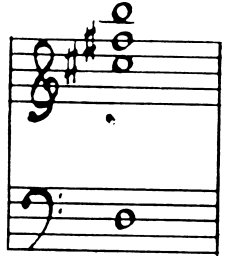

33

A SUS 7

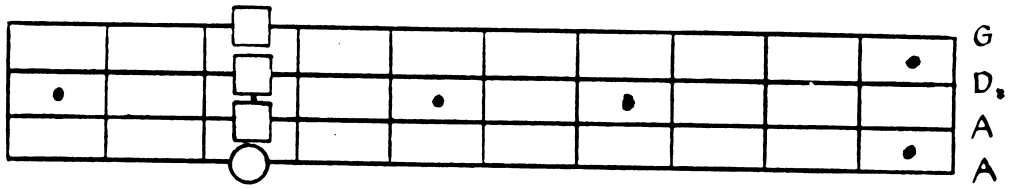

G  
D.  
A  
A

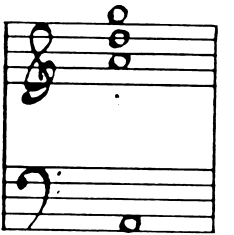

34

A SUS

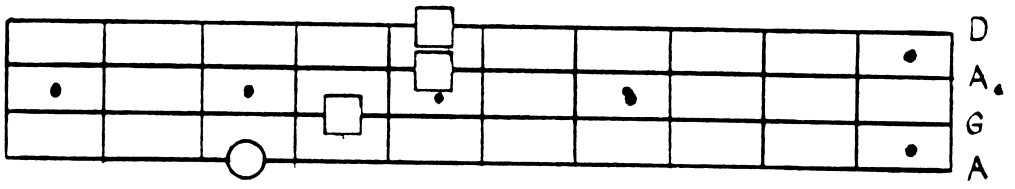

D  
A.  
G  
A

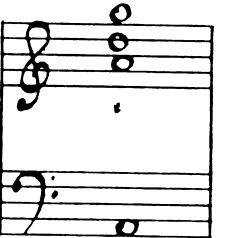

35

F -

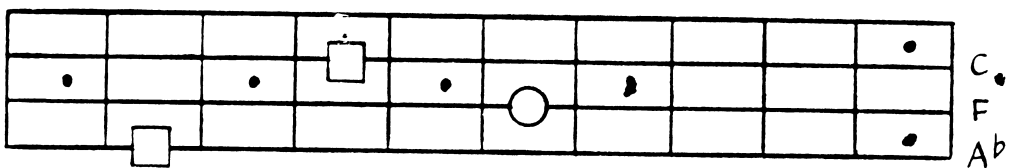

C.  
F  
Ab

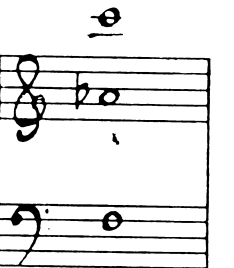

36

F - 9

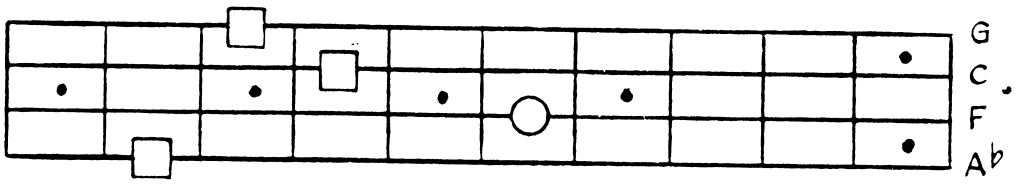

G  
C.  
F  
Ab

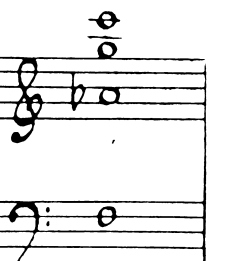

37

F# SUS

1st  
fret

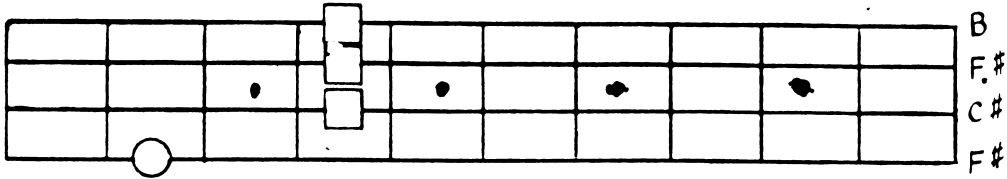

B  
F#  
C#  
F#

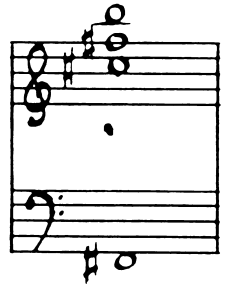

38

E MAJ TRIAD

3rd  
fret

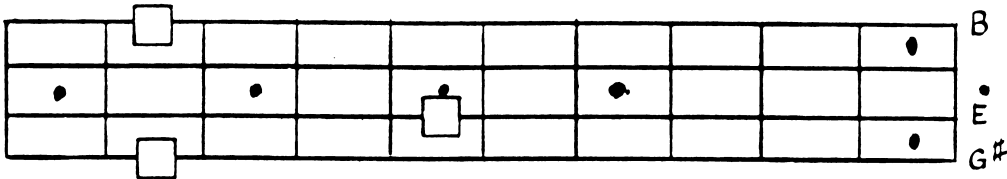

B  
E  
G#

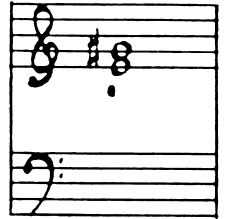

39

E MAJ 9

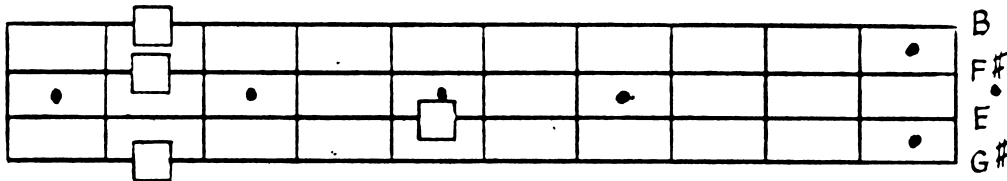

B  
F#  
E  
G#

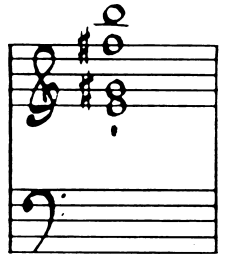

40

A<sup>b</sup> MAJ 7 #11, 13

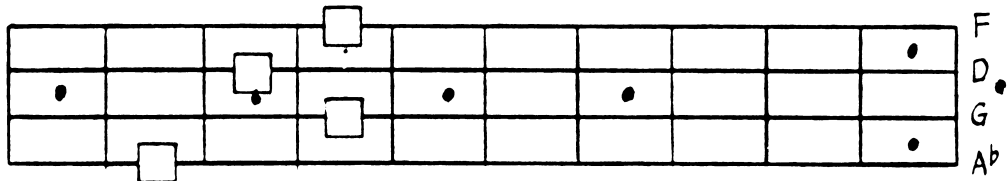

F  
D  
G  
A<sup>b</sup>



41

E DIM.

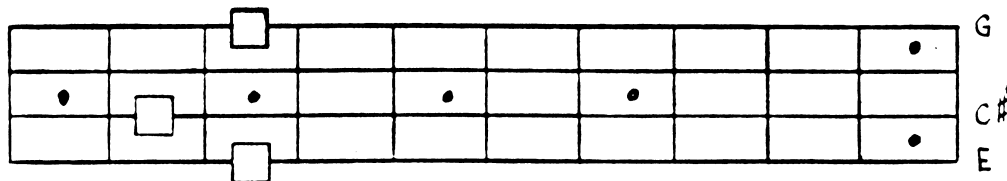

G  
C#  
E

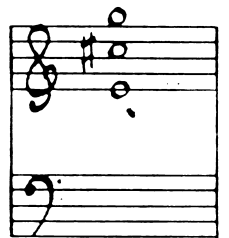

42

A<sup>b</sup> DIM.

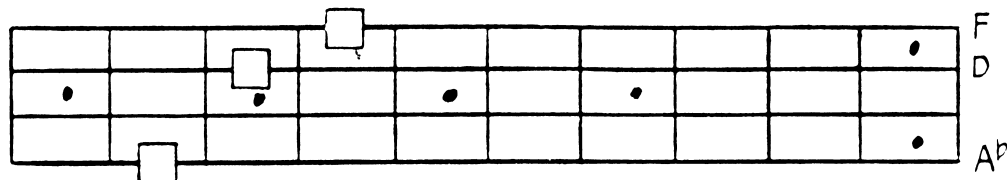

F  
D  
A<sup>b</sup>

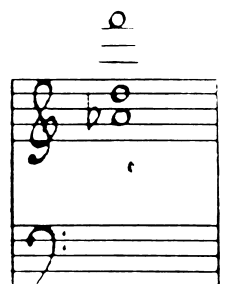

43

C<sup>o</sup>

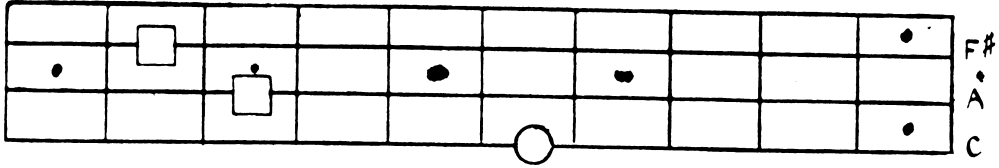

F#  
A  
A  
C

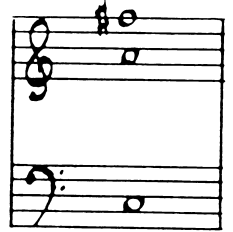

44

B<sup>o</sup>

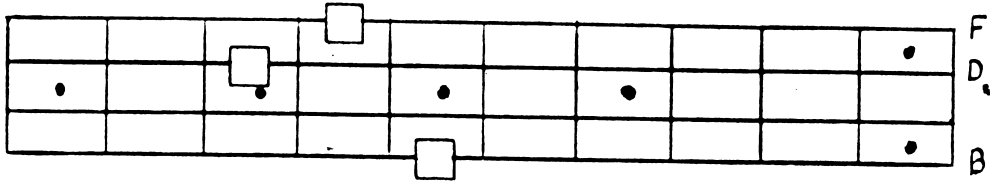

F  
D  
A  
B

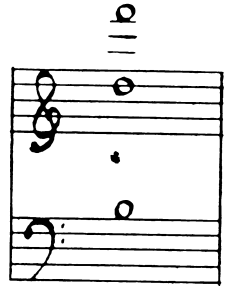

45

B MAJ 9

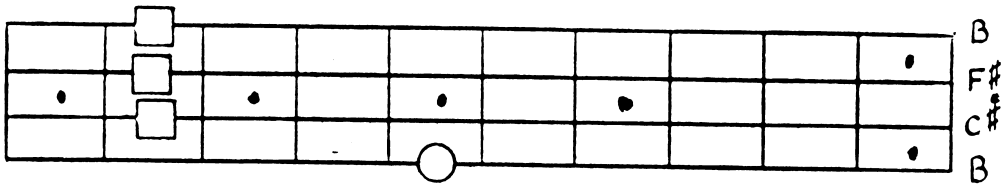

B  
F#  
C#  
B

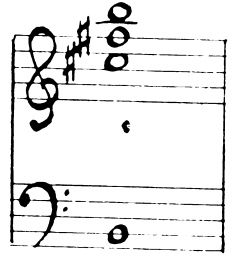

46

D MAJ 9

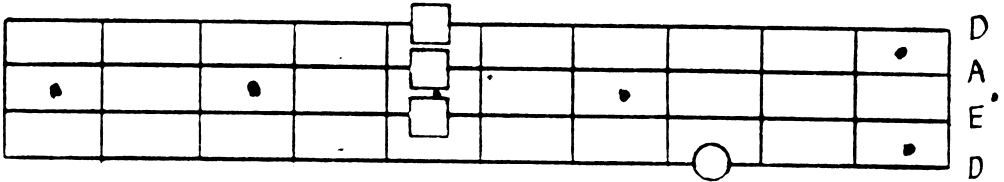

D  
A  
E  
D

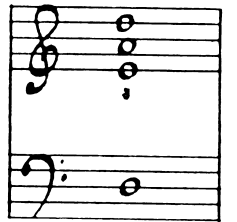

47

D<sup>b</sup> LYD

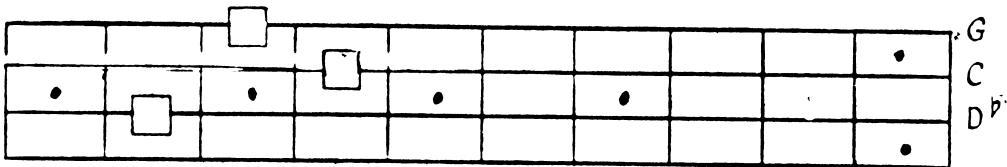

G  
C  
D<sup>b</sup>

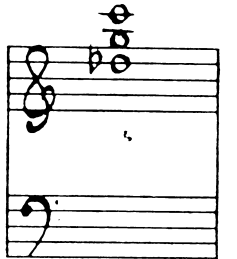

48

D<sup>b</sup> LYD

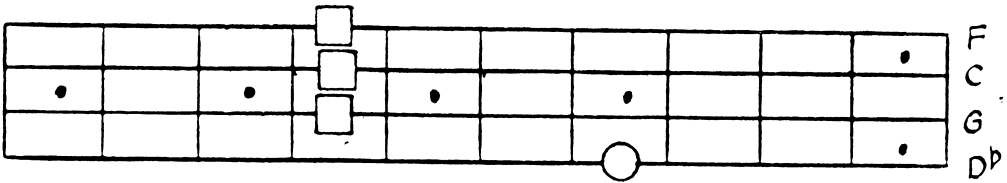

F  
C  
G  
D<sup>b</sup>

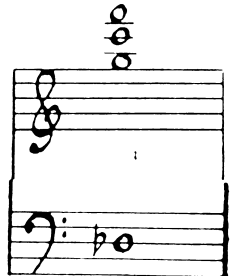

49

B<sup>b</sup>-

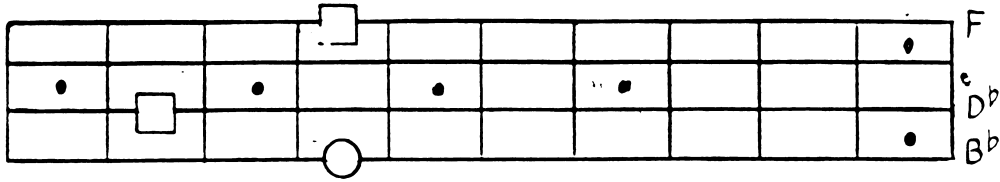

F  
D<sup>b</sup>  
B<sup>b</sup>

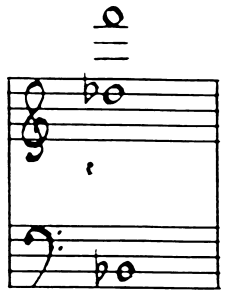

50

E<sup>b</sup>-

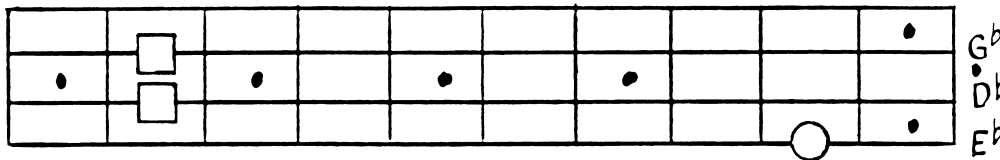

G<sup>b</sup>  
D<sup>b</sup>  
E<sup>b</sup>



51

E<sup>b</sup> 9,13

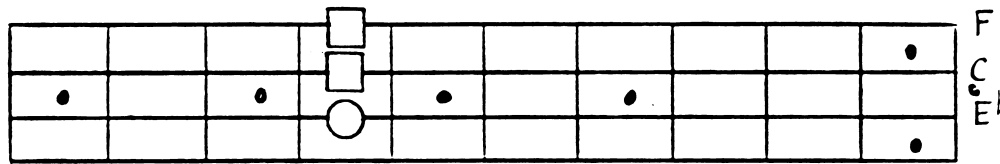

F  
C  
E<sup>b</sup>

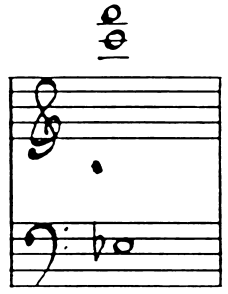

52

C MAJ 9 #11

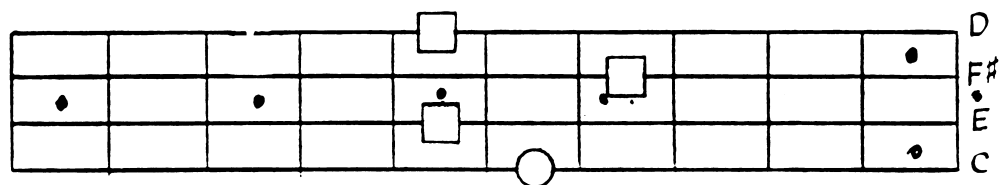

D  
F#  
E  
C

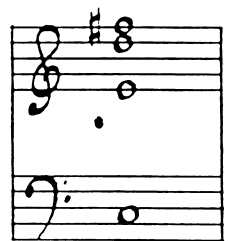

53

D<sup>b</sup>-

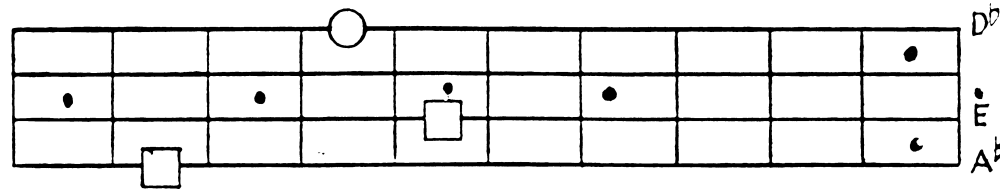

D<sup>b</sup>  
E  
A<sup>b</sup>

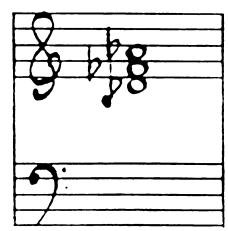

54

A SUS 9

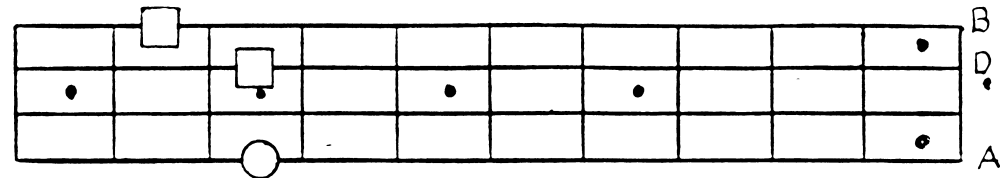

B  
D  
A

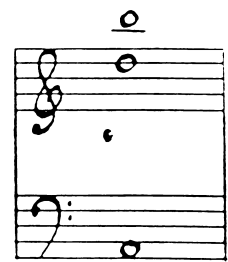

55

E<sup>b</sup>7

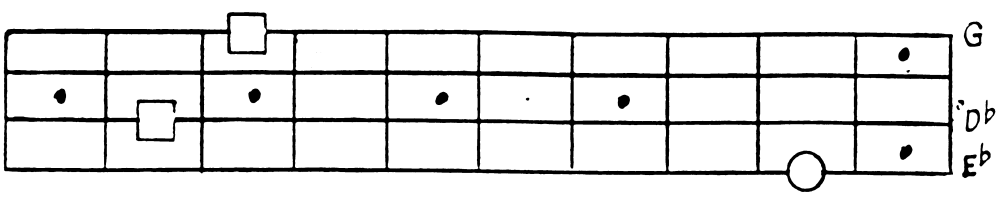

56

E<sup>b</sup>7<sup>b</sup>5

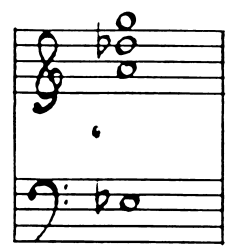
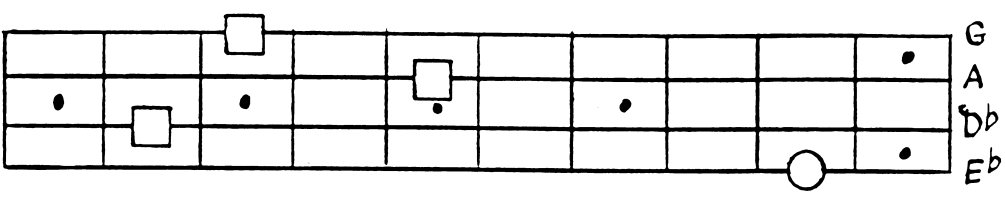

57

D MAJ 7

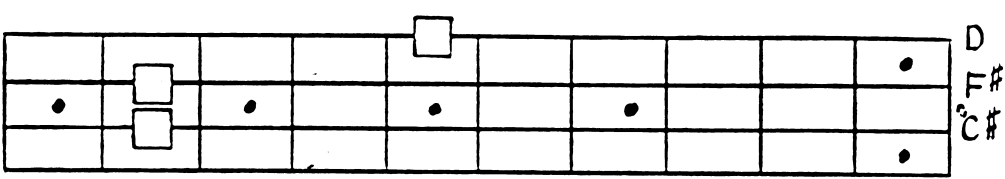

58

A MAJ 7

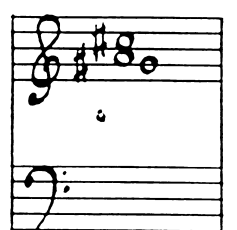
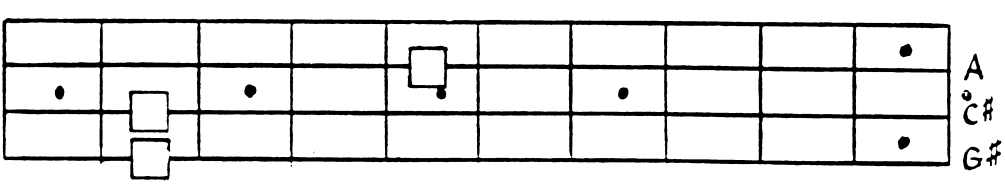

59

A<sup>b</sup>-

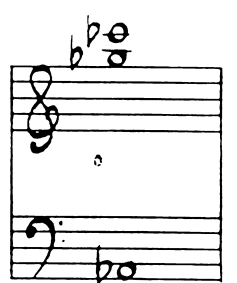
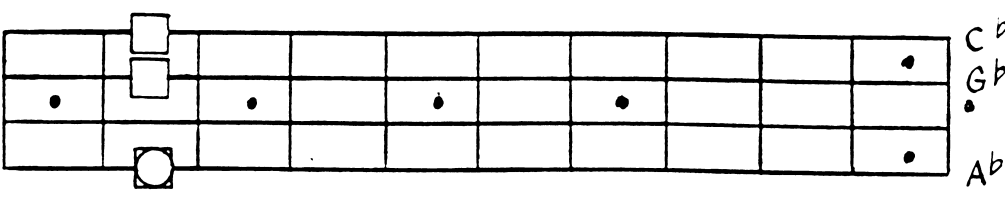

60

B-

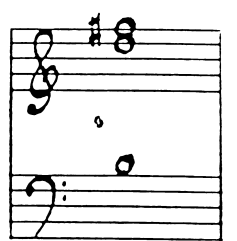
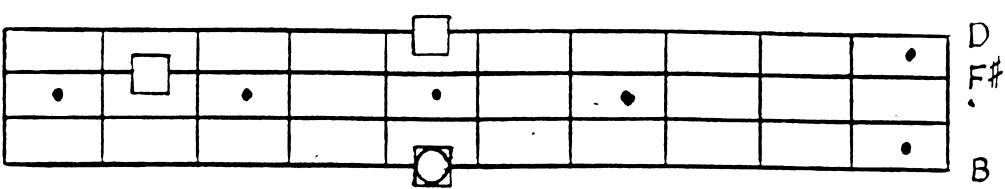



61

E<sup>b</sup>-9

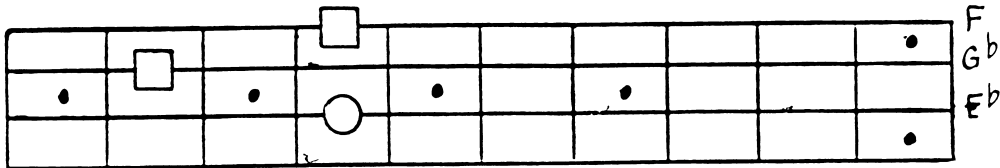

F  
G<sup>b</sup>  
E<sup>b</sup>

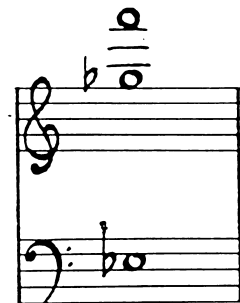

62

B<sup>b</sup>-9

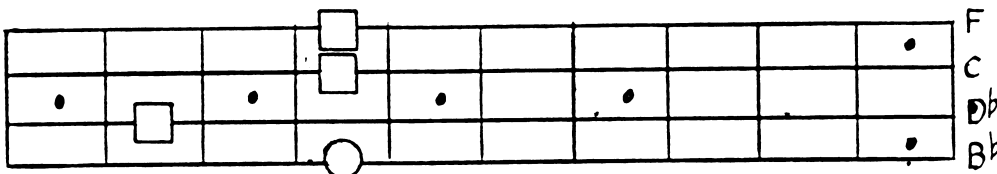

F  
C  
D<sup>b</sup>  
B<sup>b</sup>

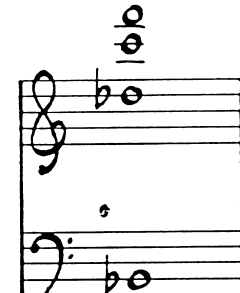

63

A-7

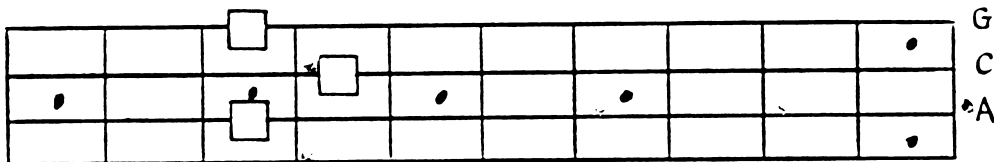

G  
C  
E<sup>b</sup>A

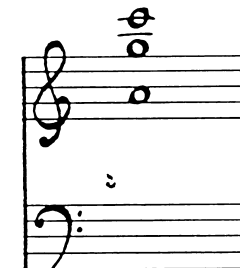

64

D<sup>b</sup> MAJ. TRIAD

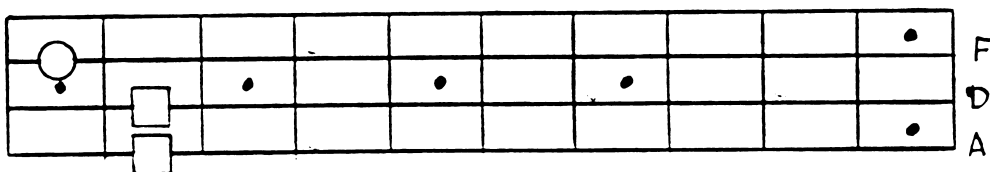

F  
D<sup>b</sup>  
A<sup>b</sup>

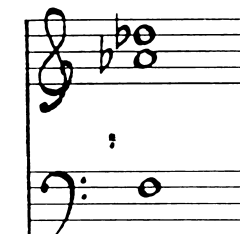

65

D<sup>b</sup>7

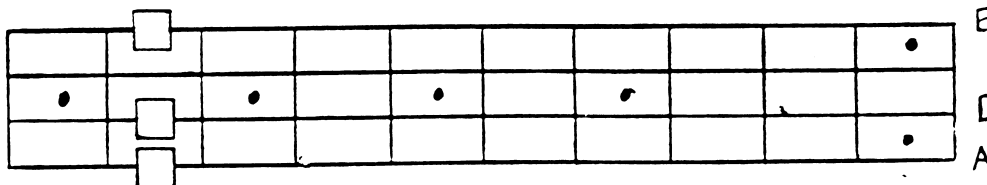

B  
D<sup>b</sup>  
A<sup>b</sup>

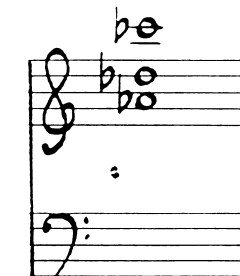

66

B<sup>b</sup>7

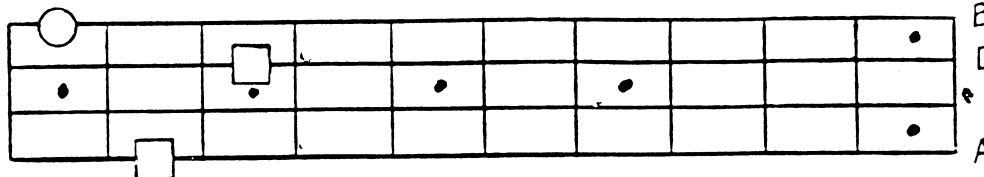

B<sup>b</sup>  
D  
A<sup>b</sup>

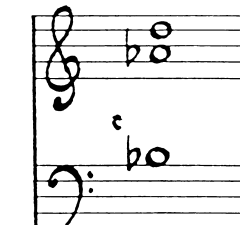

67

B<sup>b</sup>6

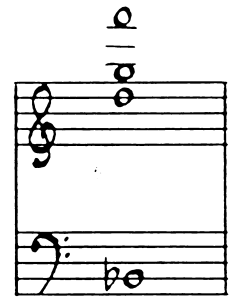
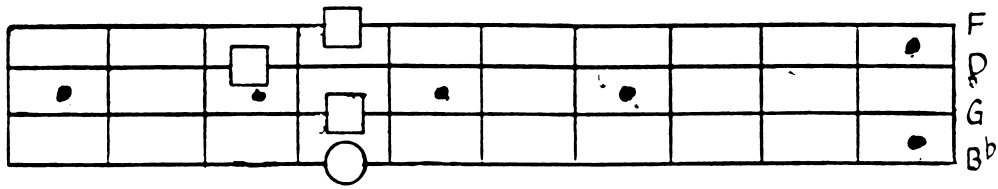

68

E-9

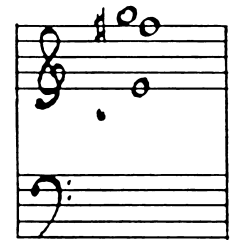
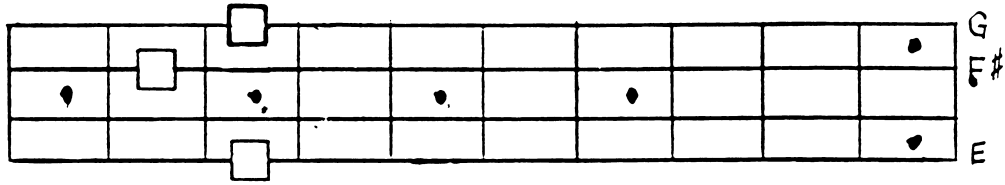

69

F-

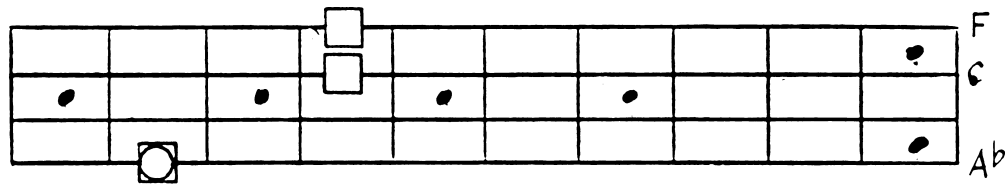

70

F#

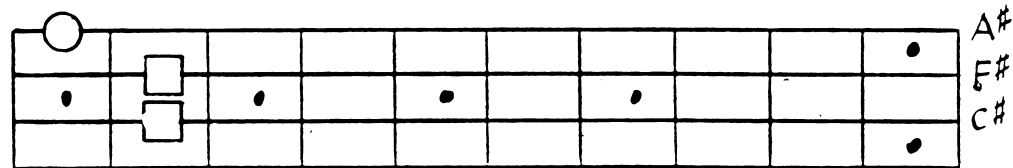

71

G-

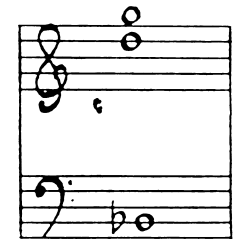
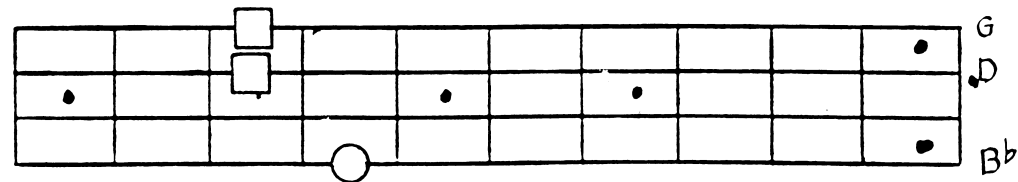

72

E MAJ9, 13

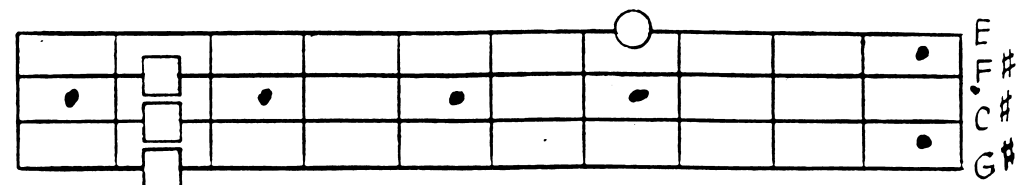

73

C-

3rd  
fret

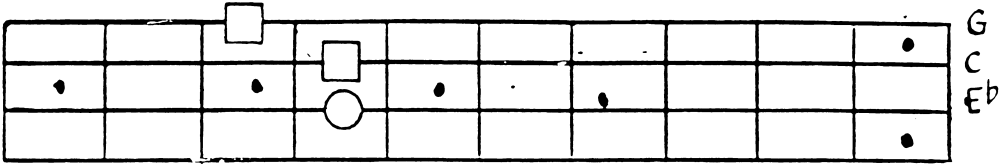

G  
C  
Eb

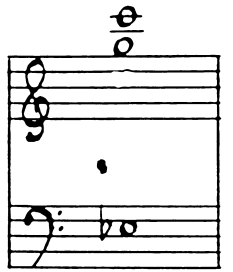

74

B MAJ. TRIAD

↓

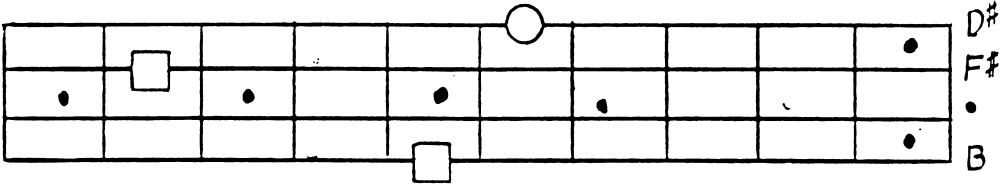

D#  
F#  
B

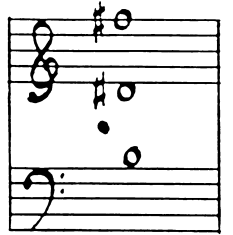

75

B MAJ. 9

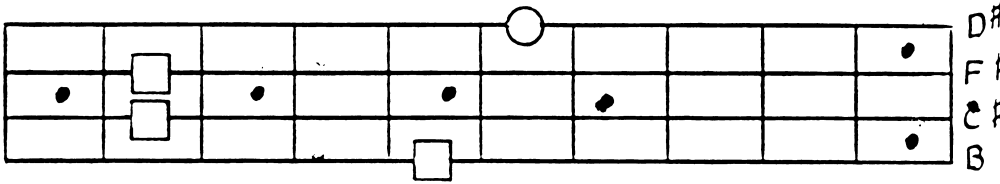

D#  
F#  
C#  
B

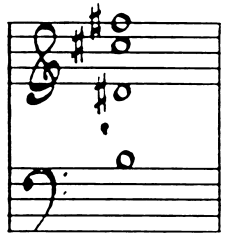

76

G MAJ 7, 13

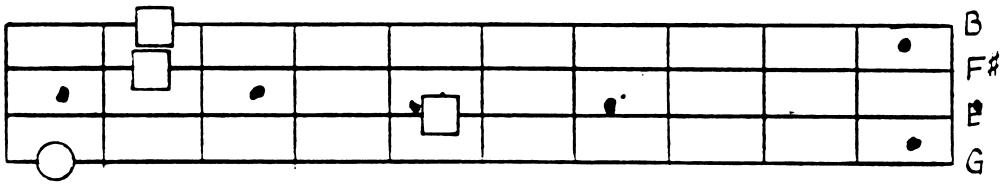

B  
F#  
D#  
G

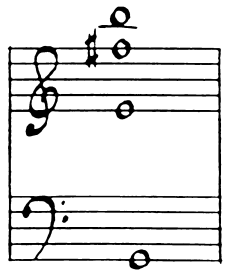

77

D7

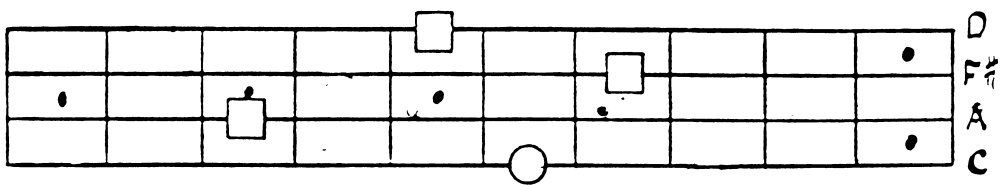

D  
F#  
A  
C

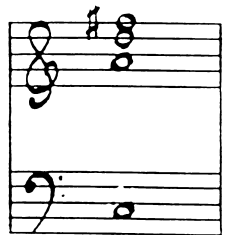

78

F6

1st  
fret

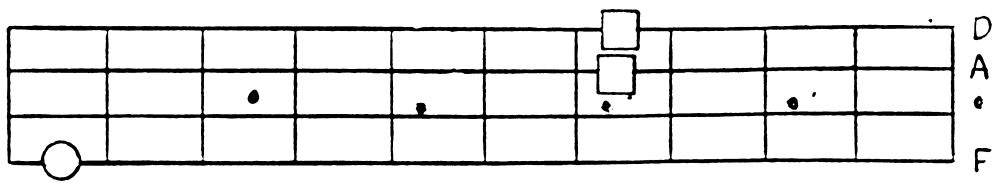

D  
A  
C  
F

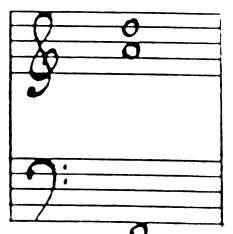

73

C-

3rd  
fret

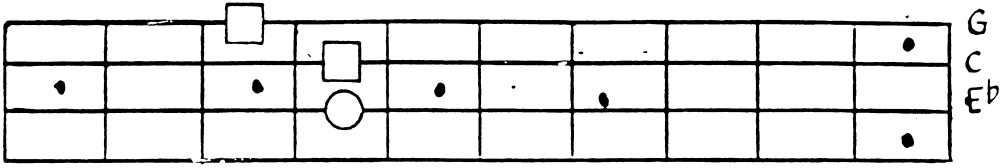

G  
C  
Eb

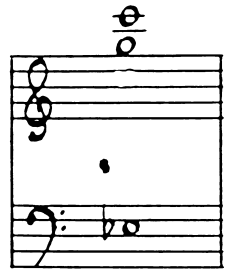

74

B MAJ. TRIAD

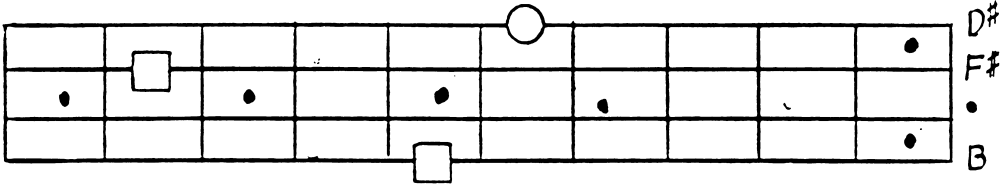

D#  
F#  
B

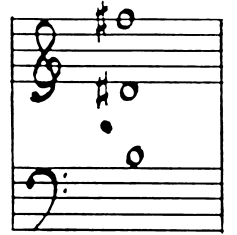

75

B MAJ. 9

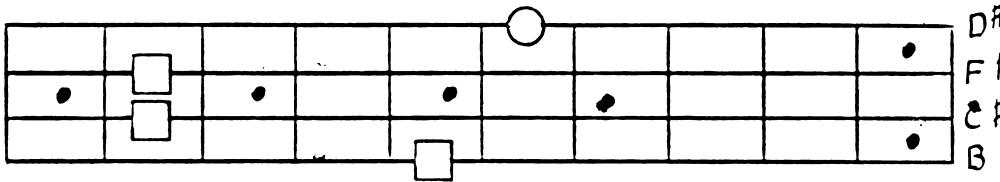

D#  
F#  
C#  
B

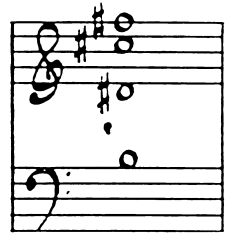

76

G MAJ 7, 13

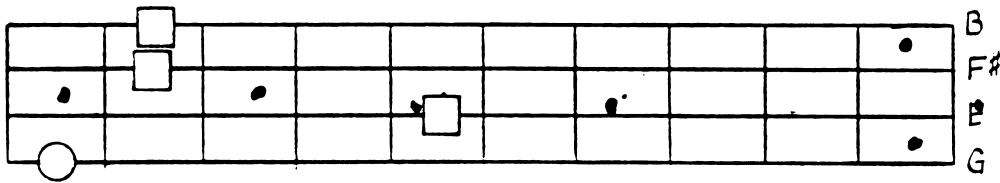

B  
F#  
D  
G

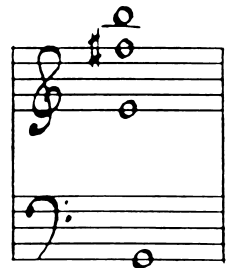

77

D7

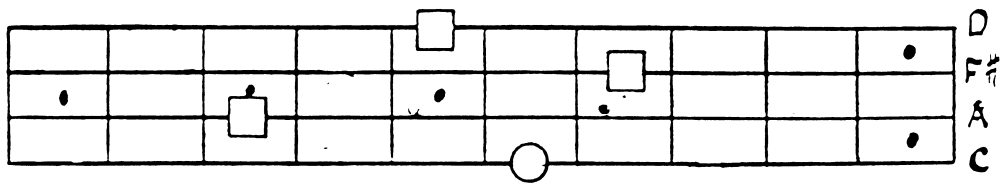

D  
F#  
A  
D

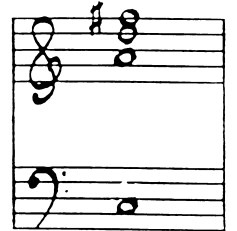

78

F6

1st  
fret

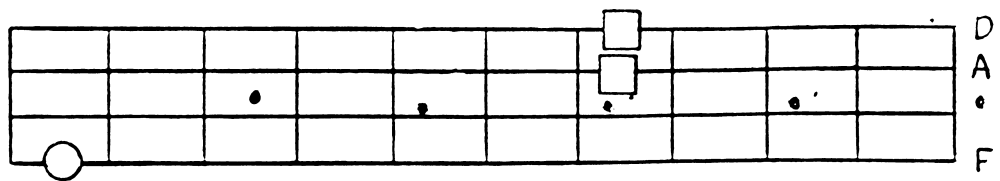

D  
A  
C  
F

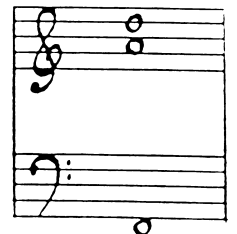

79

E7#9

3rd  
fret

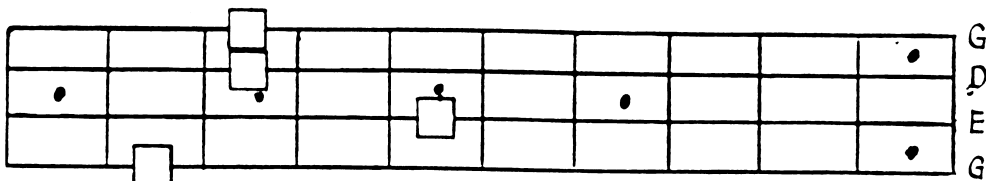

G  
D  
E  
G

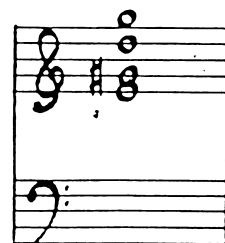

80

A<sup>b</sup>LYD

↓

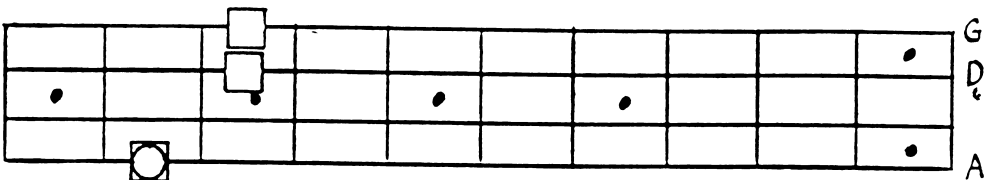

G  
D  
Ab  
G

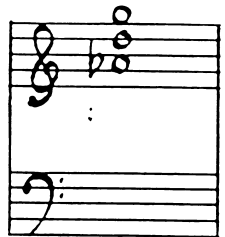

81

C AUG

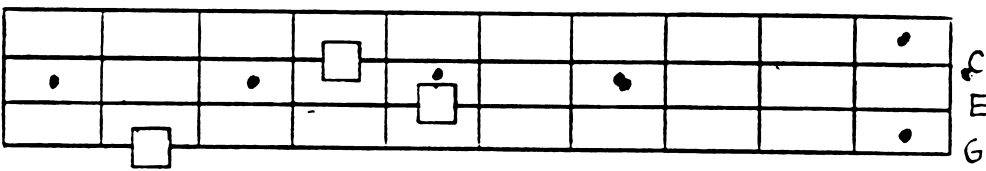

C  
E  
G#

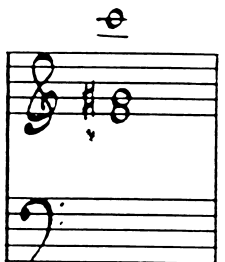

82

D<sup>b</sup>-

1st  
fret

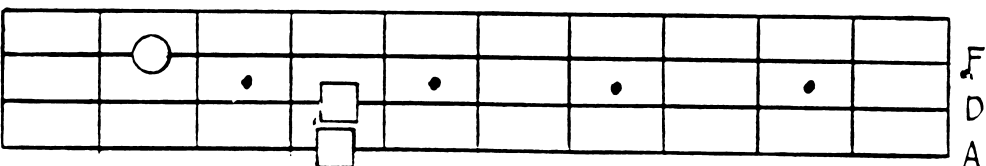

F<sup>b</sup>  
D<sup>b</sup>  
A<sup>b</sup>

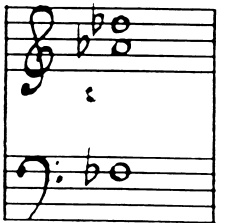

83

F#-

1 st  
fret

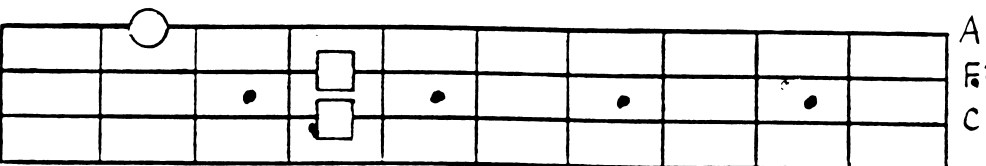

A  
F#  
C#

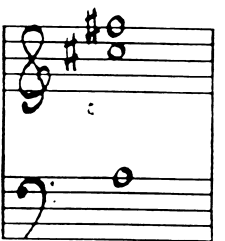

84

F#-9

↓

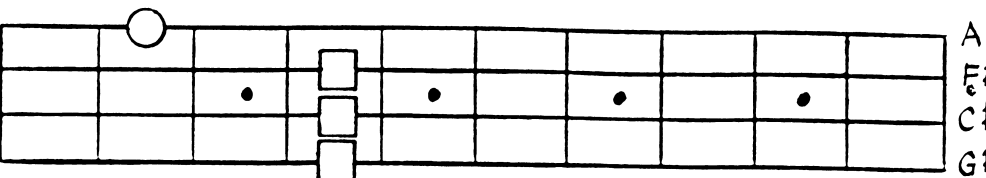

A  
F#  
C#  
G#

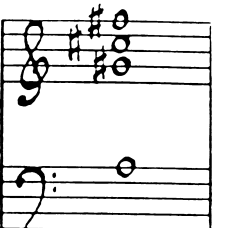

3rd  
fret



85

D MAJ TRIAD

D  
F#  
A

86

D<sup>b</sup> SUS

B  
Gb  
Db

87

B<sup>b</sup> MAJ 7, 9, 13

G  
C  
A  
Bb

88

A<sup>b</sup> 7<sup>b</sup>5

D  
Gb  
Ab

89

B<sup>b</sup> TRIAD

F  
D  
Bb

90

A<sup>b</sup> MAJ 7

G  
C  
Ab

# SCALES

A major



C major

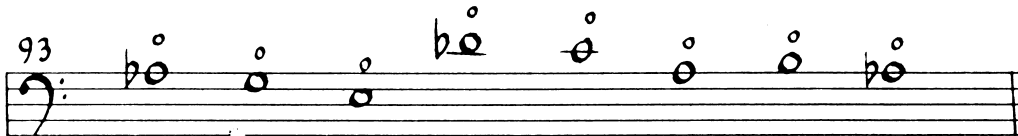

D major

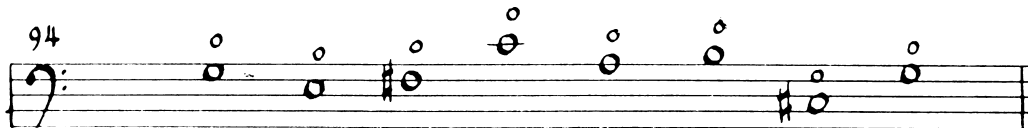

G major

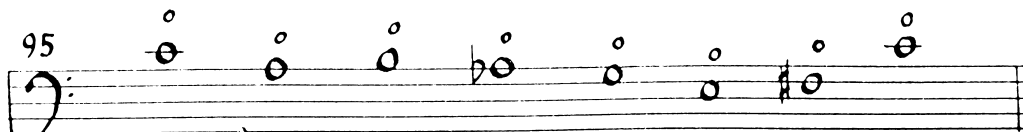

# CYCLES

96

C

F

B<sup>b</sup>

E<sup>b</sup>

Musical staff 1 for measure 96: Bass clef, 4/4 time signature. Chords: C (C4, E4, G4), F (F3, A3, C4), B<sup>b</sup> (B<sup>b</sup>3, D4, F4), E<sup>b</sup> (E<sup>b</sup>3, G3, B<sup>b</sup>3).

A<sup>b</sup>

D<sup>b</sup>

F<sup>#</sup>

B

Musical staff 2 for measure 96: Bass clef, 4/4 time signature. Chords: A<sup>b</sup> (A<sup>b</sup>3, C4, E<sup>b</sup>4), D<sup>b</sup> (D<sup>b</sup>3, F3, A<sup>b</sup>3), F<sup>#</sup> (F<sup>#</sup>3, A3, C4), B (B3, D4, F4).

E

A

D

G

Musical staff 3 for measure 96: Bass clef, 4/4 time signature. Chords: E (E3, G3, B3), A (A3, C4, E4), D (D3, F3, A3), G (G3, B3, D4).

97

C<sup>-</sup>

F<sup>-</sup>

B<sup>b-</sup>

E<sup>b-</sup>

Musical staff 1 for measure 97: Bass clef, 4/4 time signature. Chords: C<sup>-</sup> (C4, E4, G4), F<sup>-</sup> (F3, A3, C4), B<sup>b-</sup> (B<sup>b</sup>3, D4, F4), E<sup>b-</sup> (E<sup>b</sup>3, G3, B<sup>b</sup>3).

A<sup>b-</sup>

D<sup>b-</sup>

F<sup>#-</sup>

B<sup>-</sup>

Musical staff 2 for measure 97: Bass clef, 4/4 time signature. Chords: A<sup>b-</sup> (A<sup>b</sup>3, C4, E<sup>b</sup>4), D<sup>b-</sup> (D<sup>b</sup>3, F3, A<sup>b</sup>3), F<sup>#-</sup> (F<sup>#</sup>3, A3, C4), B<sup>-</sup> (B3, D4, F4).

E<sup>-</sup>

A<sup>-</sup>

D<sup>-</sup>

G<sup>-</sup>

Musical staff 3 for measure 97: Bass clef, 4/4 time signature. Chords: E<sup>-</sup> (E3, G3, B3), A<sup>-</sup> (A3, C4, E4), D<sup>-</sup> (D3, F3, A3), G<sup>-</sup> (G3, B3, D4).



# PROGRESSIONS

98

G E- A- D7

9th Fret

99

D MAJ7 B-7 E-7 A7

9th fret 7th

100

A F#- B- E7

101

A F#- B- E7

102

Eb C- F- Bb7

103

Ab F- Bb- Eb7

11th fret



# MY FAVORITES

106

107

7th POS.

108

4th pos

↑ 5th    ↑ 4th

# MY FAVORITES

## Let Notes Ring

109

110

MY FAVORITES

111

Musical notation for measures 111-113. Measure 111 is in bass clef with a common time signature. It features a complex rhythmic pattern with eighth and sixteenth notes, many of which are beamed together. Measures 112 and 113 continue this pattern, with measure 113 ending with a double bar line.

112

Musical notation for measure 112, continuing the bass clef and common time signature. It shows a continuation of the rhythmic complexity from the previous measures, ending with a double bar line.

113

Musical notation for measures 113-114. Measure 113 is in bass clef with a 4/4 time signature. It features a more melodic line with eighth and quarter notes. Measure 114 continues this melodic line, ending with a double bar line.

114

Musical notation for measure 114, continuing the bass clef and 4/4 time signature. It features a melodic line with eighth and quarter notes, ending with a double bar line.

# LICKS

G MAJ7  
115

7TH POS.  
D MAJ7  
121

D MAJ7  
116

G MAJ7 #11  
122

G MAJ7  
117

E7, 13  
123

D MAJ7  
118

E7  
124

E7 #9  
119

A7  
125

G MAJ7  
120

A7  
126

# LICKS

127 **Dsus** **G**

128 **Bsus** **E**

129 **A sus** **A**

130 **Dsus** **D**

131 **E7** **A MAJ7**

132 **Dsus** **G**

133 **Dsus** **D** **Dsus** **D**